

# Hybrid Lift Design Guide

ASME A18.1  
ASME A17.5  
NFPA 70

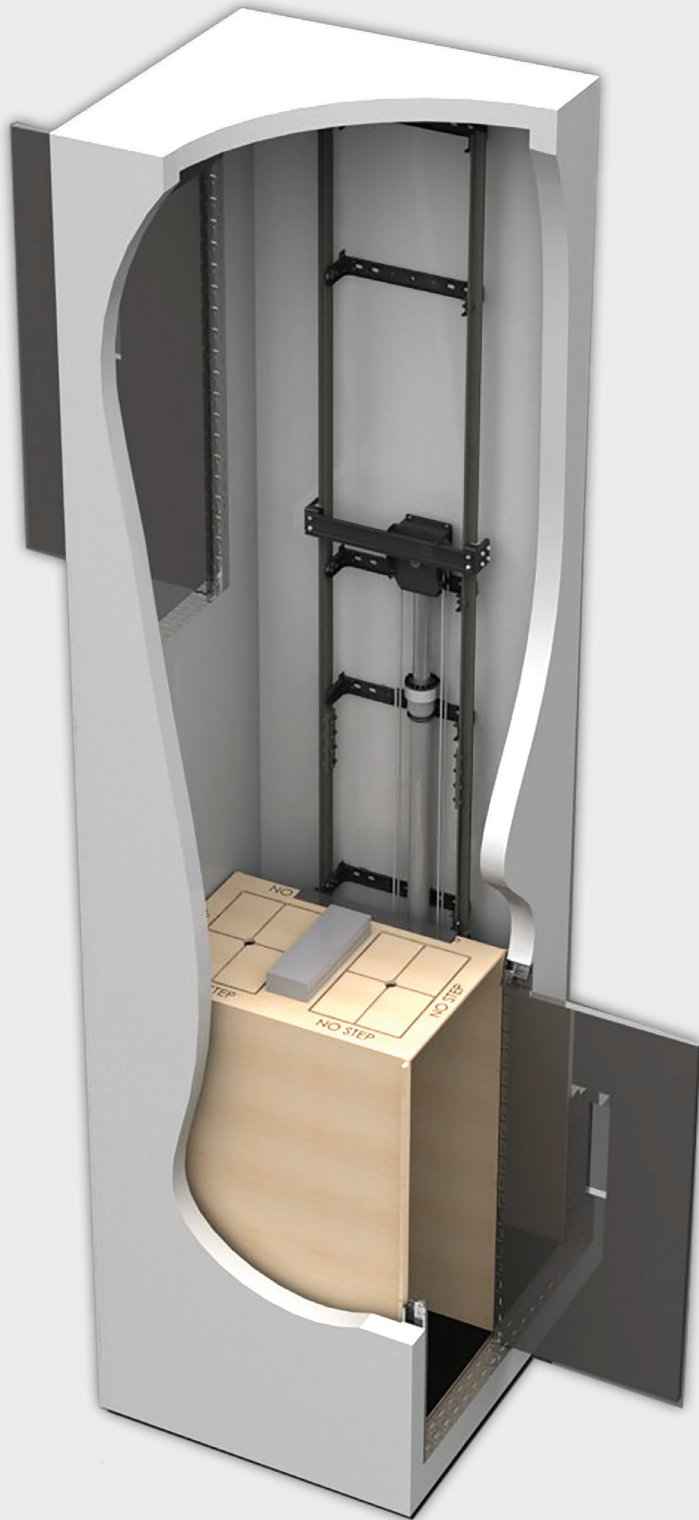

# Table of Contents

About Symmetry Elevating Solutions .....	2
Hybrid Lift Overview.....	3
General Application Rules .....	4
Common Specifications .....	5
Configurations .....	6
Hoistway -Typical Rail Backing Construction .....	7
Hydraulic Drive - Machine Rooms .....	8
Power Door Operator .....	9
Flush Door and/or Frame .....	10
Fire-Rated Flush Door.....	11

## About Symmetry Elevating Solutions

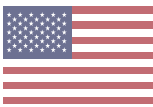
Symmetry is a beautifully crafted, expertly engineered accessibility-related product line proudly **made in the U.S.A.** at the Bella Elevator LLC manufacturing plant. Promoted and sold by our  exclusive nationwide network of carefully selected Symmetry partners and associates, Symmetry offers residential elevators, vertical platform lifts and limited use/limited application (LU/LA) elevators.

Strictly following national code guidelines and adhering to local jurisdiction requirements and variances, Symmetry products are ADA and ASME compliant and manufactured to meet the end users' specific needs. Symmetry Elevating Solutions representatives possess a wealth of knowledge and experience and are committed to excellence for the life of the product-before, during and after project completion.

With dealer locations spanning North America, we are equipped to meet the accessibility needs of a wide spectrum of clients, from home and business owners, to schools, municipalities and other governmental entities.

*Please note that this guide is for planning purposes only, applies exclusively to national code and should not be used for construction. Prior to construction, please contact your local Symmetry Elevating Solutions representative and request a job-specific set of hybrid lift plans to ensure that you obtain the accurate dimensions and requirements for your project.*

*Your representative will also assist you to identify resources to ensure that your project plans will comply with the applicable state and local codes and the permitting authorities.*

## What is a Hybrid Lift?

Whether it's commercial or residential use, Symmetry Elevating Solutions platform lifts eliminate the barrier that stairs can cause for people with limited mobility. A cost-effective solution, platform lifts create convenient access without compromising architectural character.

The Symmetry Hybrid Lift looks and feels like an elevator, but operates like a vertical platform lift. Available in many different sizes and configurations, Symmetry's Hybrid Lift features include a full height car, non-load bearing ceiling and a wide variety of optional features and finishes. Customize the doors and car to match the style and decor of your home or commercial facility.

A hybrid lift features a full-size car. The car can be built from wood or metal and customized to your personal preferences. Like an elevator, the hybrid lift also features handrails and fixtures, such as car operating panels and landing controls, available in a variety of materials and designs. Symmetry also offers the flexibility to select doors that perfectly accent the decor.

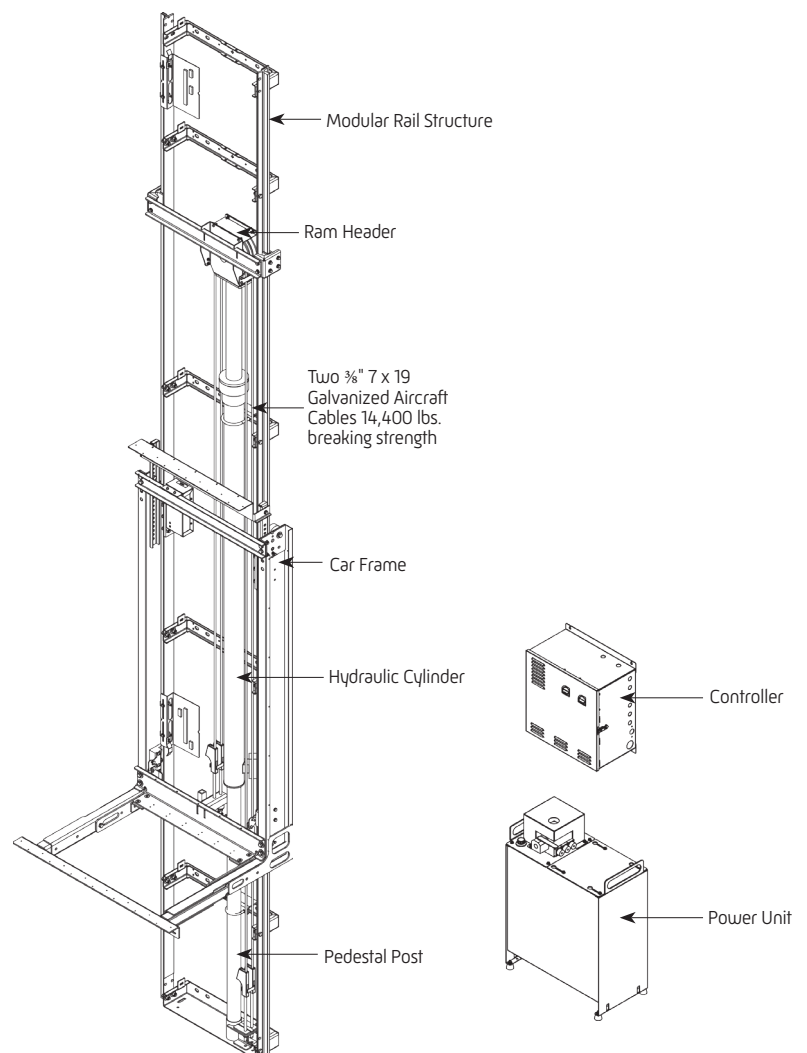

These rules have been developed as a guideline and are based on the information supplied in ICC A117.1 and ASME A18.1. Please consult your local authority having jurisdiction regarding local codes and regulations.

## Platforms

- 36" x 48" minimum clear space on platform for most applications.
- If the lift exits 90° from an entry point, the clear space must be 42" x 60".

## Doors

- 32 inch minimum clear opening for a door accessing the lift from the narrow side.
- 42 inch minimum clear opening for a door accessing the lift from the wide side.
- All doors require a minimum 18 inch latch side clearance. A greater distance may need to be provided as described in ICC A117.1.
- Power operated doors are required in applications that are not straight-through, depending on approval and layout. This includes all applications servicing more than two landings.
- Doors must have 80 inches of clear inside height.
- Doors must be installed flush to the interior of the hoistway.

## Pits

- The minimum depth of a pit will be 6 inches (8 inches preferred) from the top of the finished floor to the highest point in the pit.
- Provide a pit floor capable of withstanding the impact load of 5,277 lbs. and the static load of 2,552 lbs.
- A light fixture, light switch, and GFI duplex receptacle (provided by others) are required to comply with ASME A18.1 when the pit depth is greater than 6 inches. See code for full requirements.

## Running Clearances

- The running clearance on a side of the lift that will be used to enter/exit the lift must be 3/8 inch minimum to 3/4 inch maximum.
- The running clearance on a non-opening side of the platform must be 2 inches minimum.

## Rail Backing & General Hoistway

- Provide adequate rail backing per drawings. For vertical spans between floor systems that exceed 10 feet, please consult a structural engineer. The wall must be capable of supporting the static roller/rail loads without deflecting more than 1/8 inch.
- The hoistway must be constructed square and plumb within 1/8 inch tolerance throughout.
- The hoistway must be free of any obstructions not related to the operation of the lift. (i.e. sprinklers, pipes, ducts, etc.)
- The structure of the hoistway must allow for installation of a chain hoist to transfer materials during installation.

## Overhead

- Provide a minimum overhead of 9 inches for a 7'0" interior car height.

## Available Wood Panel Options

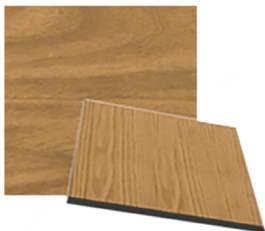

Flat Panel (Standard)



Shaker Panel (Optional)



Recessed Panel (Optional)



Raised Panel (Optional)

## Standard Features

- Travel: maximum of 14'0" (minimum 12 inches between stops)
- Speed: 30 fpm
- Rated capacity: 750-1,000 lbs.
- Pit depth: 6 inches minimum (8 inches preferred)
- Two stops
- Straight-Through opening
- Top landing ceiling overhead: 94 inches minimum
- Four-year limited parts warranty

## Safety Features

- Motor controller supply disconnects (located in controller)
- Car light supply disconnects (located in controller)
- Pit stop switch
- Car-top stop switch
- In-car emergency stop switch and alarm
- Battery backup emergency car lights and alarm
- Electromechanical hoistway door interlocks (doors by others)

## Controls

- Programmable Logic Controller (PLC)
- Constant pressure operation
- S.M.A.R.T. system (Self-Monitoring Alert Response Technology)\*
- Car Operating Panel (COP) with LED floor position indicator\*\*
- Landing controls with call button and LED floor position indicator\*\*
- Automatic car lighting
- Uninterruptible Power Supply (UPS) for car lowering (if provided) in the event of a power failure\*

## Car Features

- Car size up to 18 square feet
- 7'0" interior car height
- Birch, Oak or Maple flat veneer interior walls
- Brushed Stainless Steel handrail
- Non-load bearing ceiling
- Unfinished plywood floor with sill set for 3/8 inch (flooring by others)
- Two energy-saving recessed LED lights with Black trim rings

## Equipment

- Modular 6¼ lb. T-rail structure
- Car frame assembly
- 208/230 VAC, 60Hz, 30 amp single-phase power supply for motor controller
- 120 VAC, 60Hz, 15 amp, single-phase power supply
- Roped Hydraulic Drive system with submersed power unit

## Optional Features

- Custom car heights
- Up to four stops
- Shaker, Recessed or Raised panel car with matching ceiling
- Four recessed LED lights with Black, Polished Brass, Brushed Nickel or Bronze trim rings
- Factory-finished car
- Polished Stainless Steel, Polished or Brushed Brass, Black, Vintage Bronze and Oil-Rubbed Brass fixtures (including COPs, landing controls and handrails)
- ADA phone
- Custom wood interiors
- Custom factory finishes\*
- "Green" material alternatives and finishes for car interiors\*
- Buffer springs (require minimum of 8¼ inch pit depth)
- Key switch for COP and/or landing controls
- Fire retardant on car (required for units installed in fire-rated shafts)
- Egg crate ceiling

## Enter/Exit Configurations

- Straight-Through standard
- 90° Adjacent optional
- Enter/Exit same side optional

\* Denotes exclusive features

\*\* Standard finish is Brushed Stainless Steel, but multiple finishes available



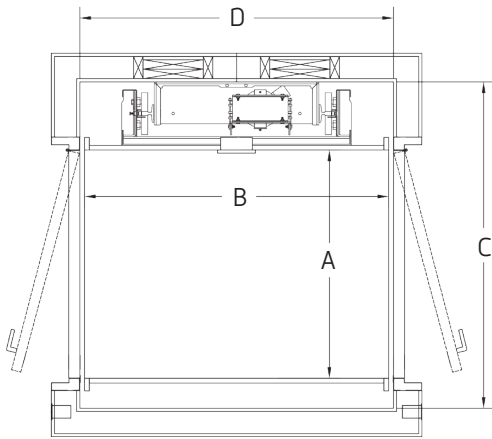

### Straight-Through

Clear Platform Width A	Clear Platform Length B	Finished Hoistway Width C	Finished Hoistway Length D
36"	48"	50½"	49½"
36"	54"	50½"	55½"
36"	60"	50½"	61½"
42"	60"	56½"	61½"
40"	54"	54½"	55½"

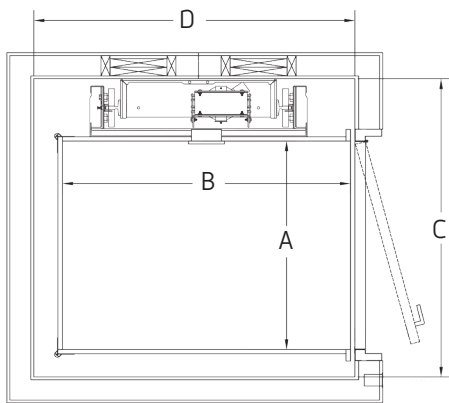

### Enter/Exit Same Side

Clear Platform Width A	Clear Platform Length B	Finished Hoistway Width C	Finished Hoistway Length D
36"	48"	50½"	52"
36"	54"	50½"	58"
36"	60"	50½"	64"
42"	60"	56½"	64"
40"	54"	54½"	58"

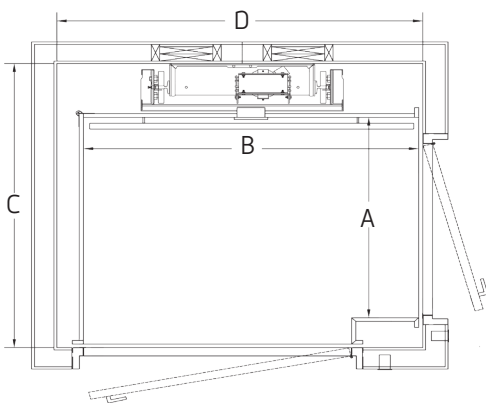

### 90° Exit

Clear Platform Width A	Clear Platform Length B	Finished Hoistway Width C	Finished Hoistway Length D
36"	60"	53½"	64½"
42"	60"	59½"	64½"

Note: In a 90° Exit Configuration 36" x 60" is only available for code years prior to 2009.

# Hoistway

## Typical rail backing construction

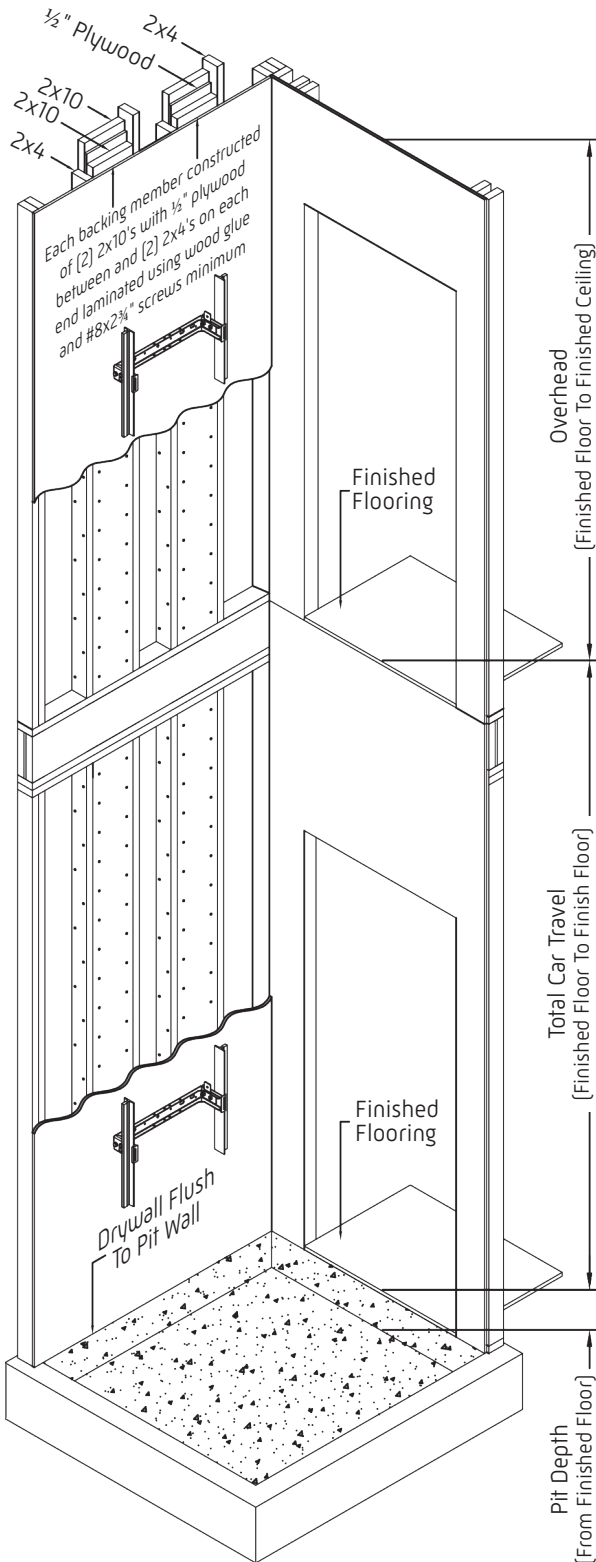

Each backing member constructed of (2) 2 x 10's with 1/2 inch plywood between and (2) 2 x 4's on each end laminated using wood glue and #8 x 2 3/4" screws, 2 per row minimum, spaced on 6 inch vertical centers.

Installing 1/2 inch plywood behind the drywall will improve the sound deadening and strengthen the hoistway.

The specified loads are based on the worst case load condition of 1,000 lb. capacity, 925 lb. car and frame weight and a 60 inch cantilever car.

The assumptions made relative to the standard backing arrangement are a maximum span of 10 feet, a minimum wood modulus of elasticity of  $1.95 \times 10^6$  psi (Douglas Fir) and stiffening factor from the unit's rail structure based on the bracket spacing.

If the backer span exceeds 10 feet or if the backing construction and/or materials are not as specified, please consult a structural engineer.

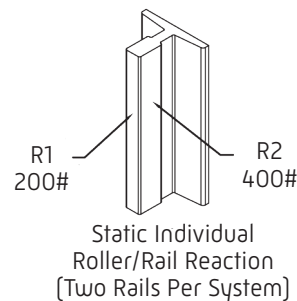

## Standard Machine Room

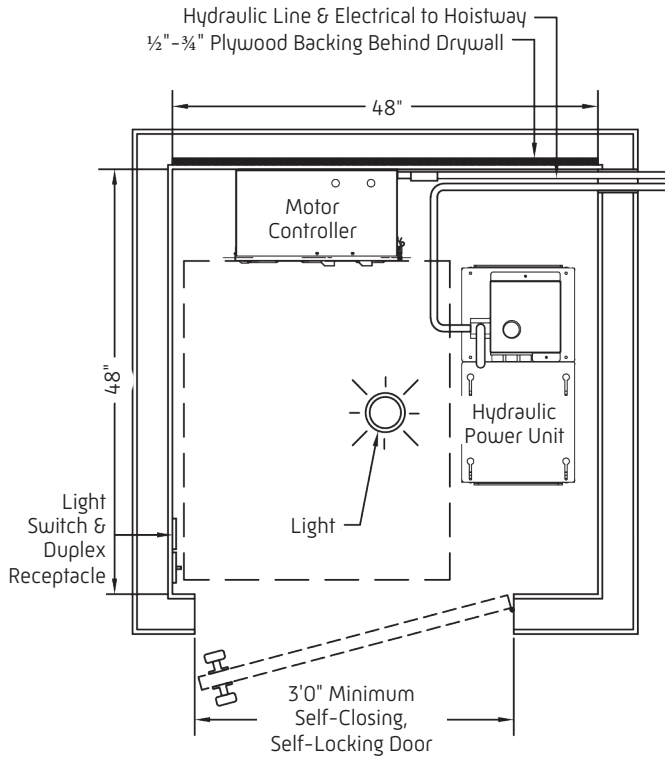

## Compact Machine Room

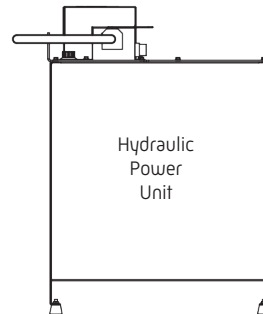
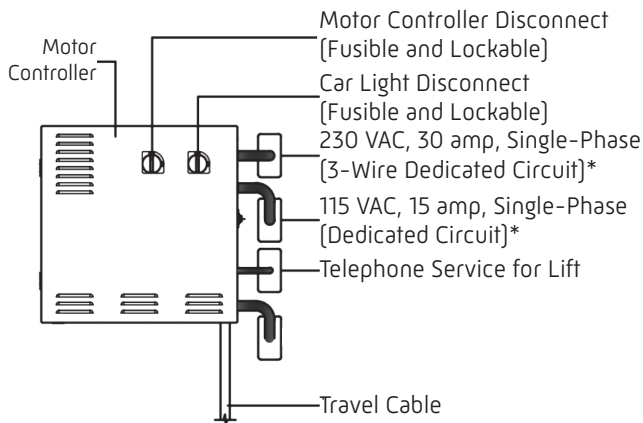
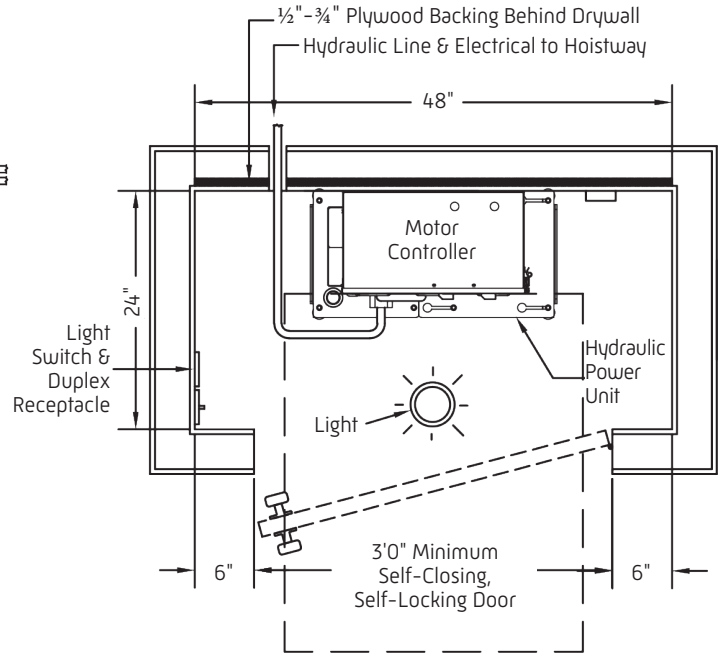

**Motor Controller**  
 Standard - 18"W x 18"H x 10"D  
 Alternate - 22"W x 30"H x 8"D

**Hydraulic Power Unit**  
 24 $\frac{1}{4}$ "W x 33 $\frac{1}{2}$ "H x 12 $\frac{3}{4}$ "D

### Notes:

- 1) The elevator machine room location and layout must meet the code requirements defined by the local authority having jurisdiction.
- 2) 30" wide x 36" deep clear working space in front of the motor controller as required by National Electrical Code (NFPA 70).
- 3) The light switch must be located on the strike side of the machine room door.
- 4) The hydraulic power unit must be located within 40'0" of the cylinder.
- 5) The machine room must be free of all equipment not related to the lift.
- 6) The machine/control room temperature must be maintained between 50°F and 80°F.

\*Feeding breaker must not be a G.F.I.





## Standard Features

- In 90° or enter/exit same side applications, the doors are required to have an automatic door operator
- Indoor use
- Automatic reopen/reclose upon contact with an obstruction
- Opening/closing time: Approximately 8 seconds
- Adjustable hold open time
- Capable of manual pull to open
- Low-energy operator
- Power-open
- Spring-close
- Self-monitoring microprocessor-based control

*Please note that this guide is for planning purposes only, applies exclusively to national code and should not be used for construction. Prior to construction, please contact your local Symmetry Elevating Solutions representative and request a job-specific set of hybrid lift plans to ensure that you obtain the accurate dimensions and requirements for your project.*

*Your representative will also assist you to identify resources to ensure that your project plans will comply with the applicable state and local codes and the permitting authorities.*

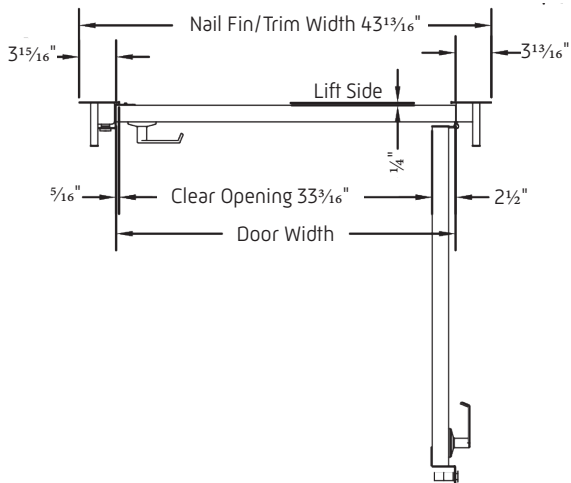
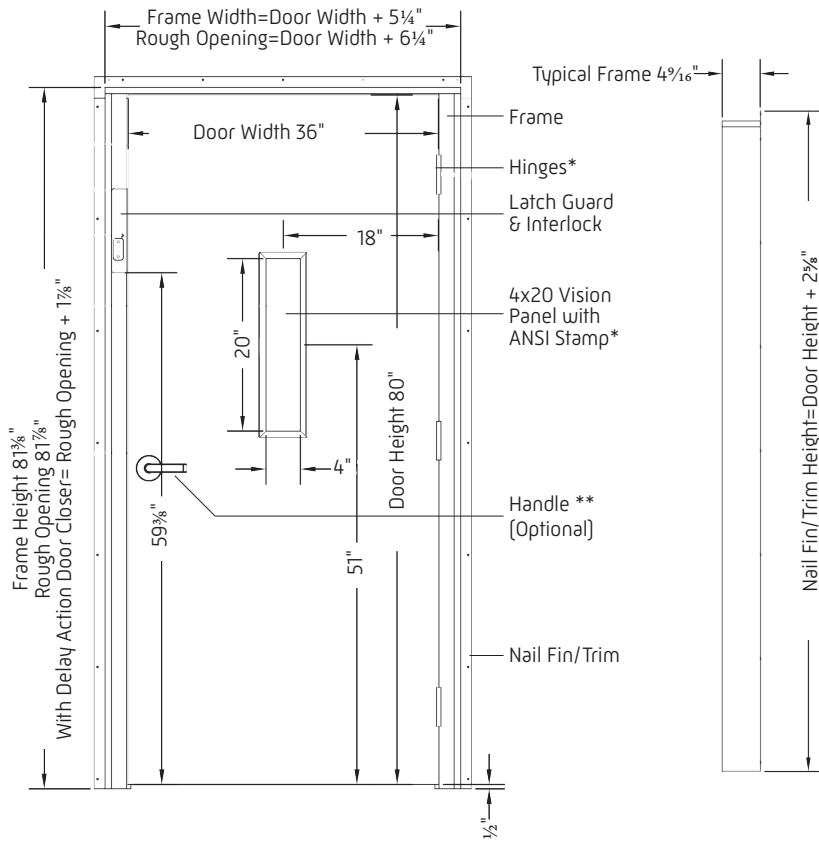

Latch Guard  
(Exterior View)



Electro-Mechanical  
Interlock (EMDL)



Dummy Handle  
(Optional)

## Notes:

- 1) LH shown/RH opposite
- 2) The door/frame is suitable for installation in masonry or wood frame construction
- 3) The door/frame is installed with the door flush to the inside of the hoistway
- 4) The interior hoistway wall should be finished up to the rough opening
- 5) Door closer or power door operator required for code compliance
- 6) Available as a frame only or complete door with frame

\* Hinges provided only with complete door package.

\*\* Handle optional with frame, but included with complete door package.

# Fire-Rated Flush Door

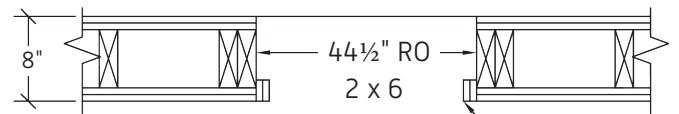
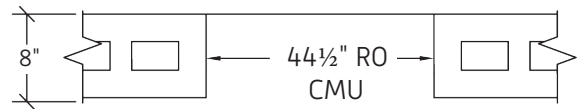
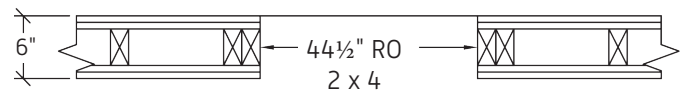
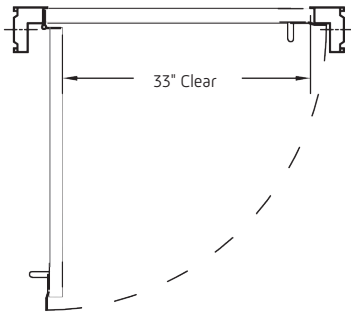
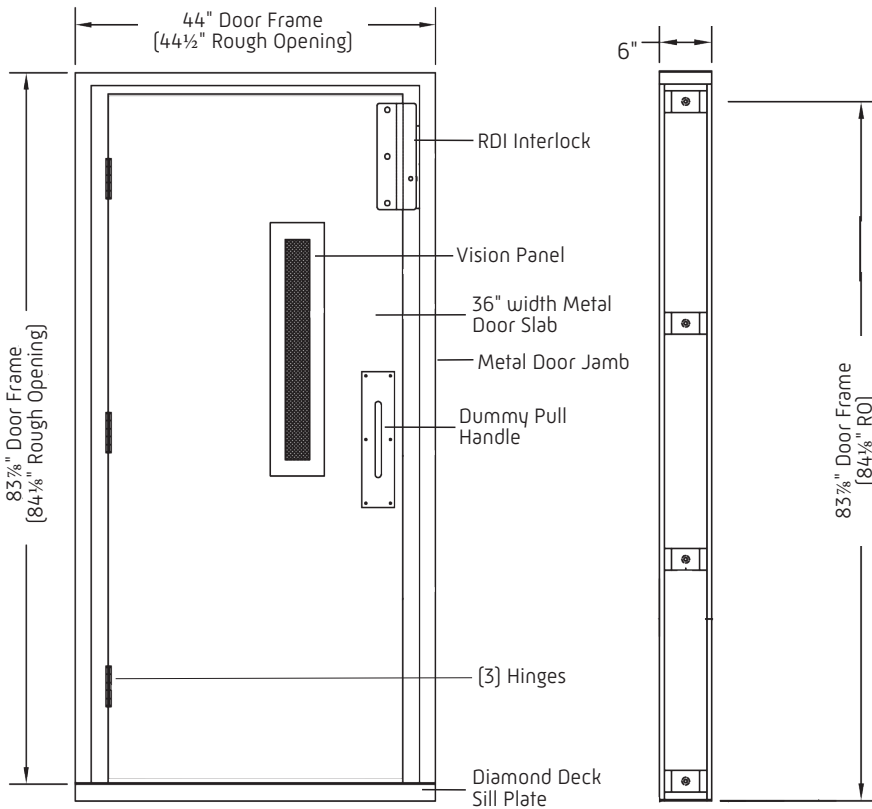

Add drywall strips after frame set

## Notes:

- 1) RH shown/LH opposite
- 2) Door is suitable for installation in masonry or wood frame construction
- 3) The door frame is installed with the door flush to the inside of the hoistway
- 4) The interior hoistway wall should be finished up to the rough opening
- 5) Door closer or power door operator required for code compliance
- 6) Trim sill plate as needed for low profile lift installations